

SKT315~335M6-20/PR

PERC Monocrystalline
60Cells All Black PV Module PLUS



315~335 Watt



*BLACK FRAME/BLACK BACK-SHEET PRODUCTS ARE AVAILABLE UPON REQUEST



MANAGEMENT SYSTEM



ISO 9001: Quality management system



ISO 14001: Standard for environmental management system



OHSAS 18001: International standard for occupational health and safety assessment system

PRODUCT CERTIFICATES



WARRANTY

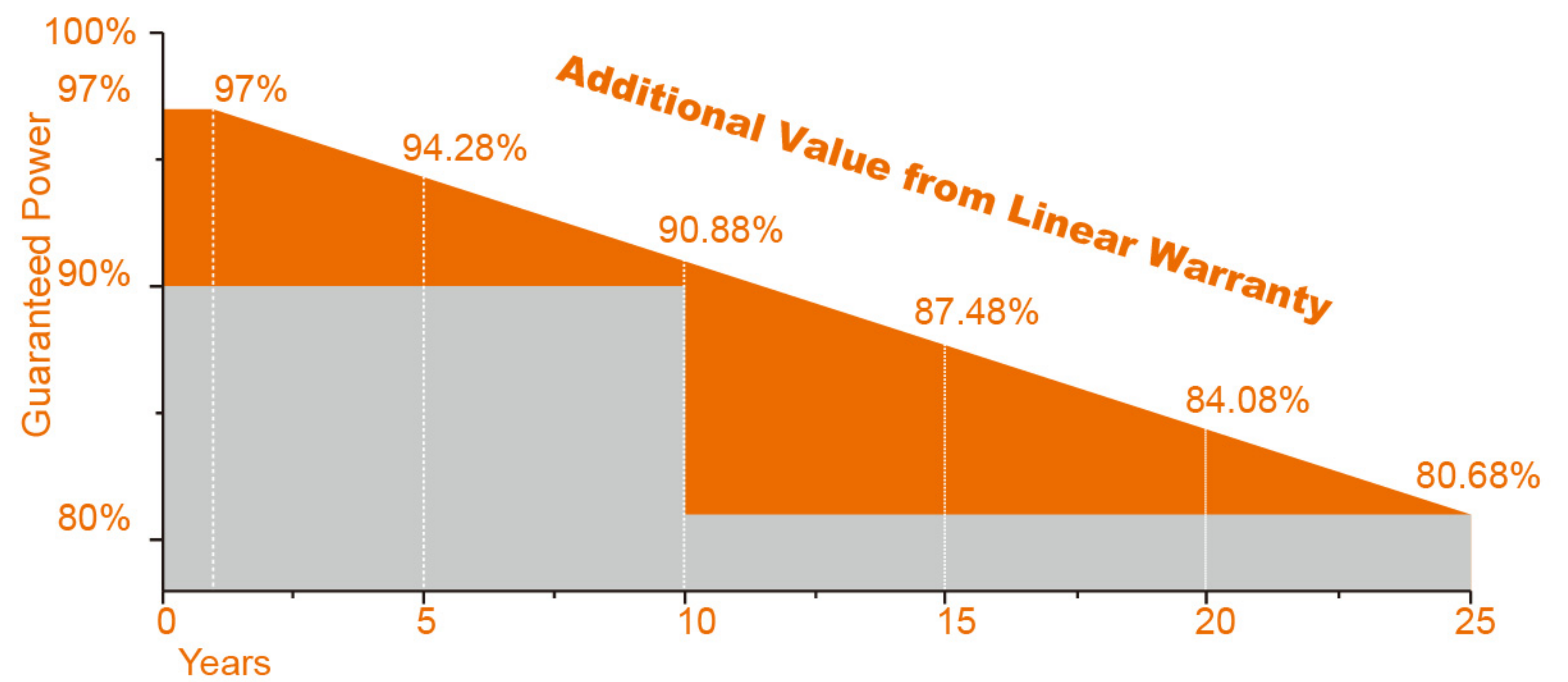

12 Years
Material & Craft
Quality
assurance

12 Years
90% Output
Power
guarantee

25 Years
80% Output
Power
guarantee

Safety



Safety for salt mist corrosion
(IEC61701, tested in TUV)

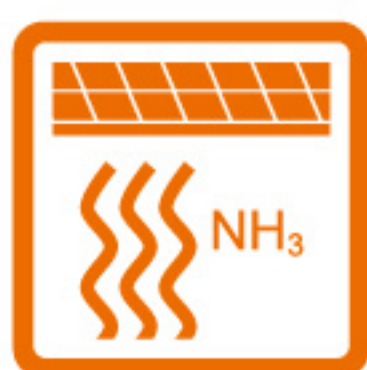

Safety for ammonia corrosion
(IEC62716, tested in TUV)



Safety for fire risk
(Class A, tested in TUV)

Key



High stability of the aluminium
frame



High quality junction box and
connector systems



100% inspection, to guarantee
the reliability of solar systems

Technology



Using high efficiency mono
solar cells



Excellent performance in
low-light environments



High transmissivity, low-iron
tempered glass.

Specifications are subject to change without further notification SKT-EN-2019V1.0 © Copyright 2019 Sunket

Electrical Characteristics (STC)

Module Type	SKT315M6-20	SKT320M6-20	SKT325M6-20
Maximum Power- Pmax(W)	315	320	325
Open Circuit Voltage - Voc(V)	40.7	40.9	41.1
Short- Circuit Current - Isc(A)	10.04	10.15	10.20
Voltage at Pmax -Vmp(V)	33.2	33.4	33.6
Current at Pmax - Imp(A)	9.49	9.59	9.68
Module Efficiency -ηm (%)	18.88	19.18	19.48

Module Type	SKT330M6-20	SKT335M6-20
Maximum Power- Pmax(W)	330	335
Open Circuit Voltage - Voc(V)	41.3	41.5
Short- Circuit Current - Isc(A)	10.31	10.36
Voltage at Pmax -Vmp(V)	33.8	34.0
Current at Pmax - Imp(A)	9.77	9.87
Module Efficiency -ηm (%)	19.78	20.08

STC: Irradiance 1000W/m², Cell Temperature 25°C, Air Mass 1.5

Power Tolerance(W)	(0,+3%)
Maximum System Voltage(V)	1000/1500
Maximum Series Fuse Rating (A)	20

Temperature Characteristics

Pmax Temperature Coefficient	-0.37%/°C
Voc Temperature Coefficient	-0.28%/°C
Isc Temperature Coefficient	+0.048%/°C
Operating Temperature	-40~+85°C
Nominal Operating Cell Temperature(NOCT)	45±2°C

Mechanical Specifications

External Dimensions	1665×1002×35 mm
Weight	19.0 kg
Solar Cells	Mono crystalline 158.75×158.75mm (60pcs)
Front Glass	3.2 mm tempered glass, low iron
Frame	Anodized aluminum alloy
Junction Box	IP67
Output Cables	4.0 mm ² , cable length: 1000 mm
Connector	MC4 Compatible
Mechanical Load	5400 Pa

Packing Configuration

	1665×1002×35mm	
Container	20'GP	40'GP
Pieces per Pallet	31	31
Pallets per Container	12	28
Pieces per Container	372	868

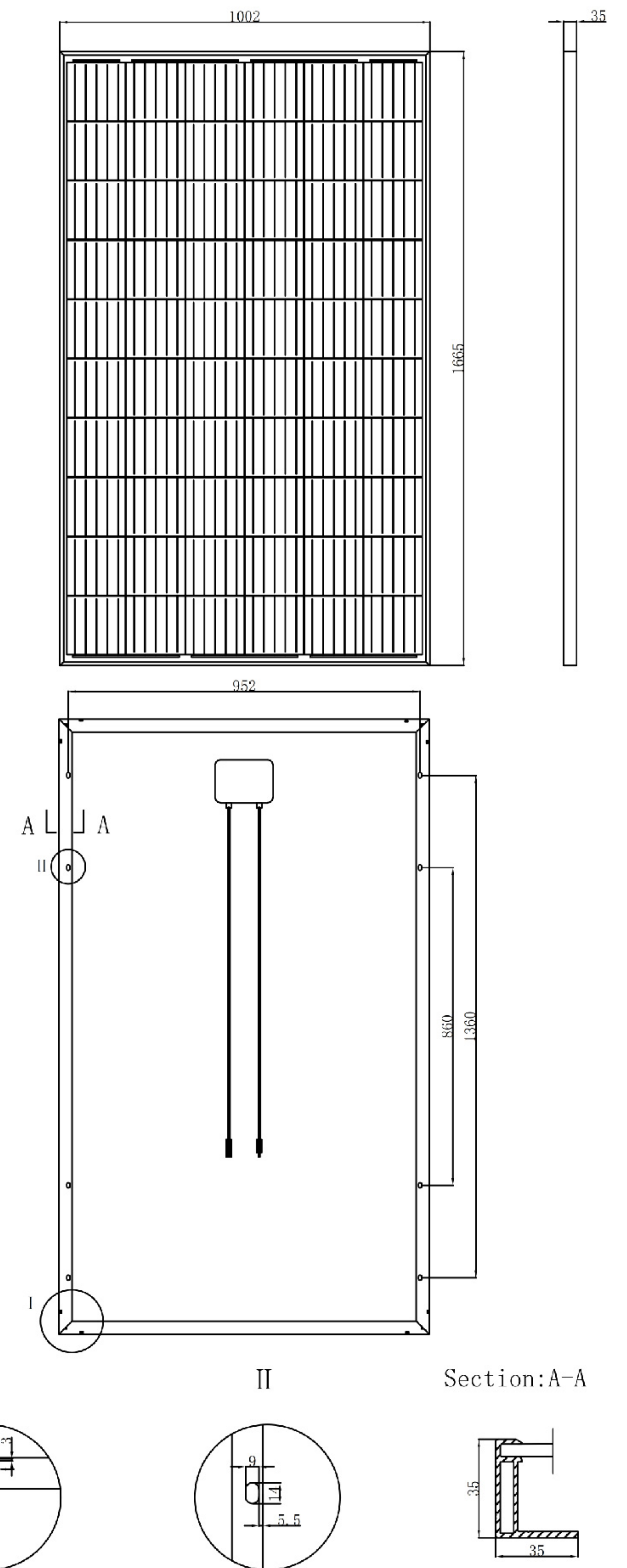

All Dimensions in mm(inch)
The above drawing is a graphical representation of the product.
For engineering quality drawings please contact SUNKET.

Current-Voltage & Power-Voltage Curves (325W)

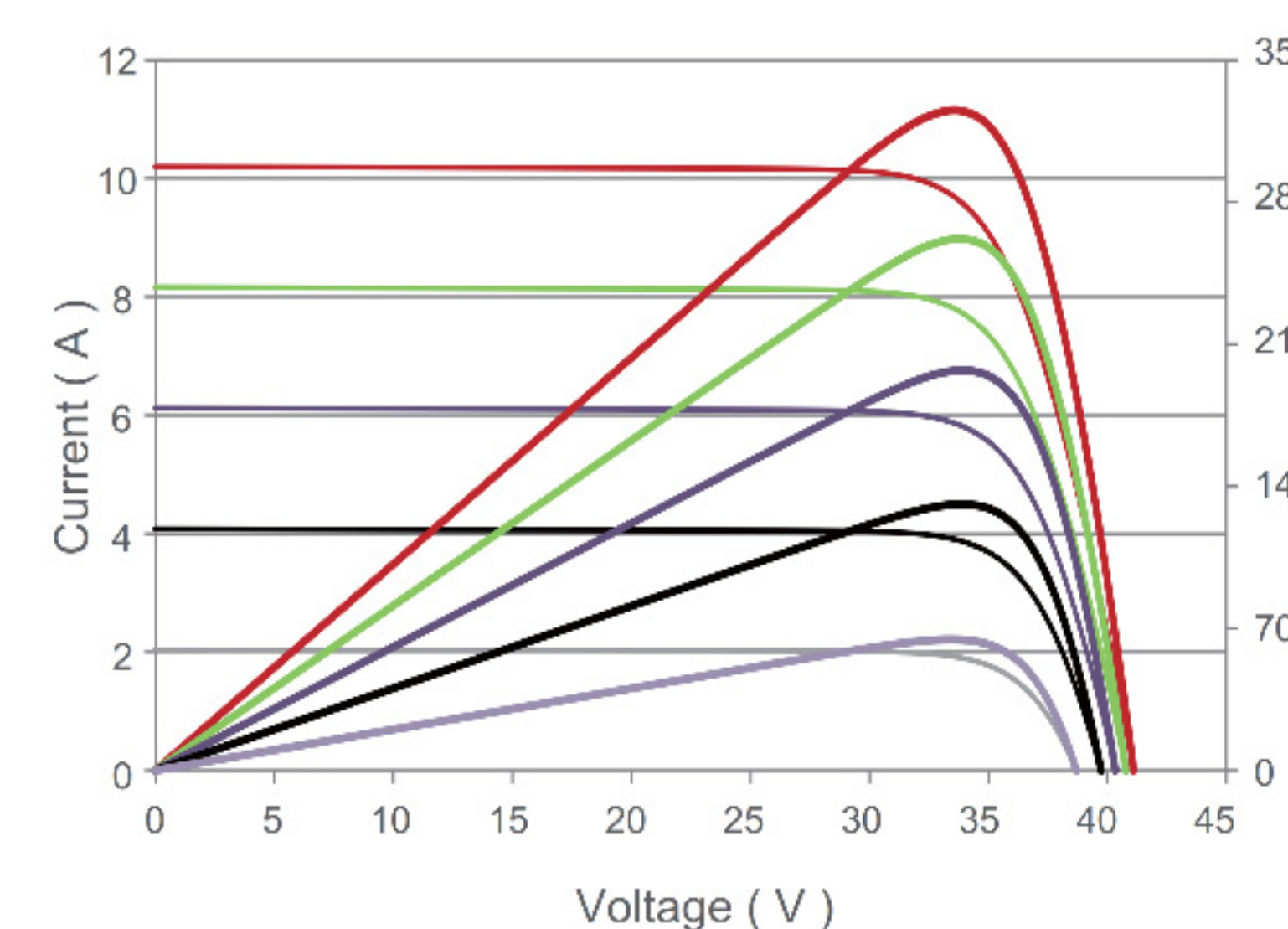

Temperature Dependence of Isc, Voc, Pmax

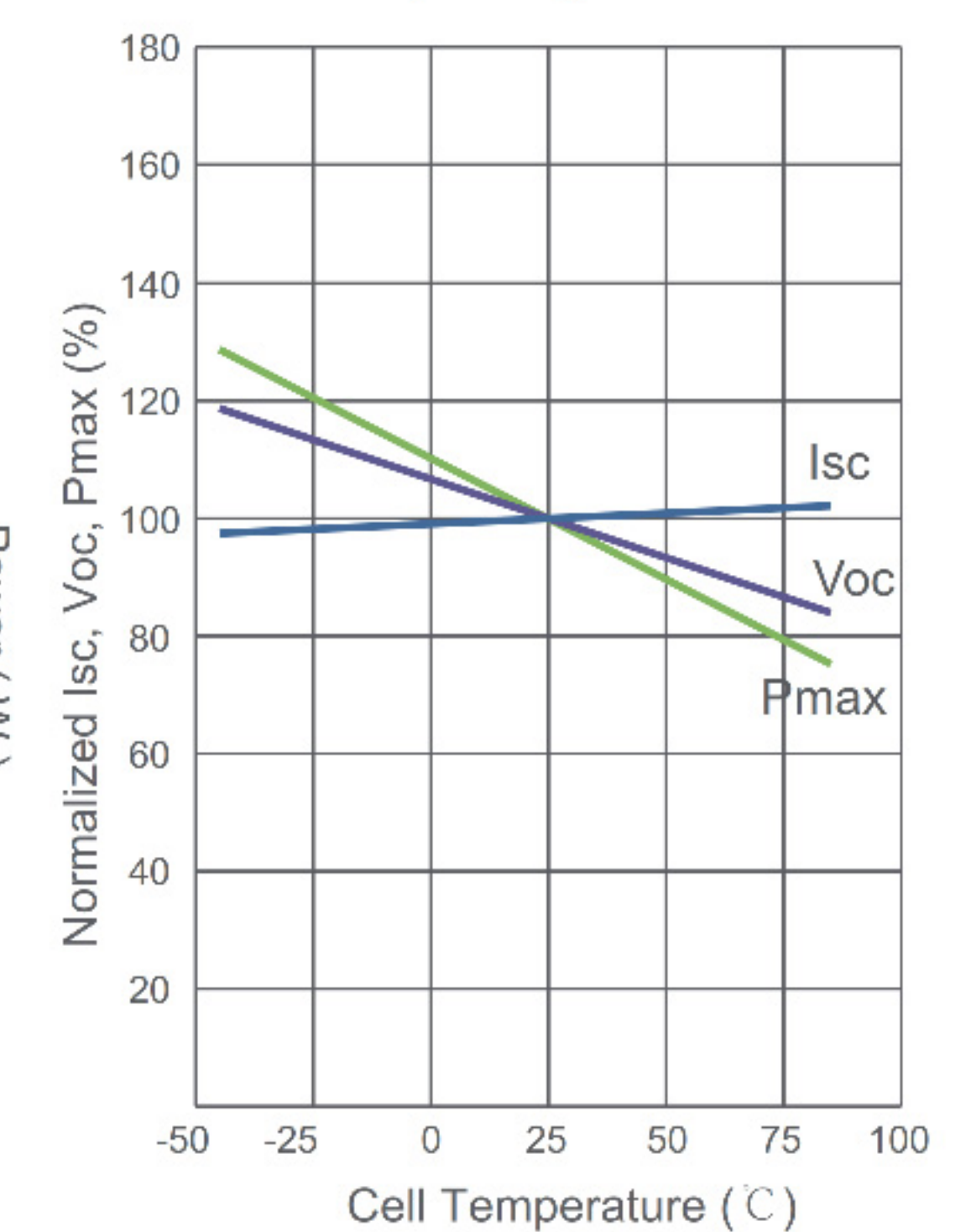

Specifications are subject to change without further notification SKT-EN-2019V1.0 © Copyright 2019 Sunket